

DESCRIPTION

The multiple pumps are available in STANDARD and T.C. (short-tandem) versions.

The versatility of our pumps permits the assembling of a multiple pump using a single pump and making only a simple operation of disassembly/assembly.

- All our standard pumps are already present to engage another pump.
- A very limited quantity of kit "flange connections and accessories" gives a small stock value and mainly a rapid assistance to final users.

- The total of the torque absorbed by each pump shall be not in excess of the max. allowed torque on main shaft (see below scheme)

The max. torque absorbed by the follow pumps shall be not in excess of the torque transmitted by the rear draft gear.

- The power absorbed by the multiple pump is determined from total powers that each pump absorbed and it is calculated as follow:

$$P = \frac{c \times n \times p}{603000}$$

in which:

P = Max. absorbed power (Kw)

c = Pump displacement (cm³/rev)

n = Max. working speed (rpm)

p = Max. working pressure (bar)

TECHNICAL FEATURES

- Performance of units composing multiple pumps are the same as these of the corresponding single pumps.
- Max. rotation speed of multiple pumps is given by slower pump.
- Max. torque absorbed by each simple unit to grant a working limit at max. working pressure is calculated in the following way:

$$M = \frac{c \times p}{64}$$

in which:

M = Max absorbed input torque (ft.lbs)

c = Pump displacement (cm³/rev)

p = Max. working pressure (bar)

	Torque transmitted by the draft pump [Nm] (ft.lbs)								Torque transmitted by rear draft [Nm] (ft.lbs)
	Type 10	Type 11	Type 12	Type 13	Type 14	Type 15	Type 16	Type 17/27	
GR 1	18 (13.3)	18 (13.3)		30 (22.1)	30 (22.1)	30 (22.1)		12 (8.9)	18 (13.3)
GR 2	98 (72.3)	98 (72.3)	98 (72.3)	98 (72.3)	98 (72.3)	98 (72.3)	98 (72.3)	70 (51.6)	75 (55.3)
GR 3	240 (177)			240 (177)	240 (177)				240 (177)
GR 4	750 (553)								750 (553)

ORDERING CODE – TANDEMS

Tandem STANDARD

Are possible different combinations of all the group pumps (Gr.1 - Gr.2 - Gr.3 and Gr.4).
The suction of each pump is independent.

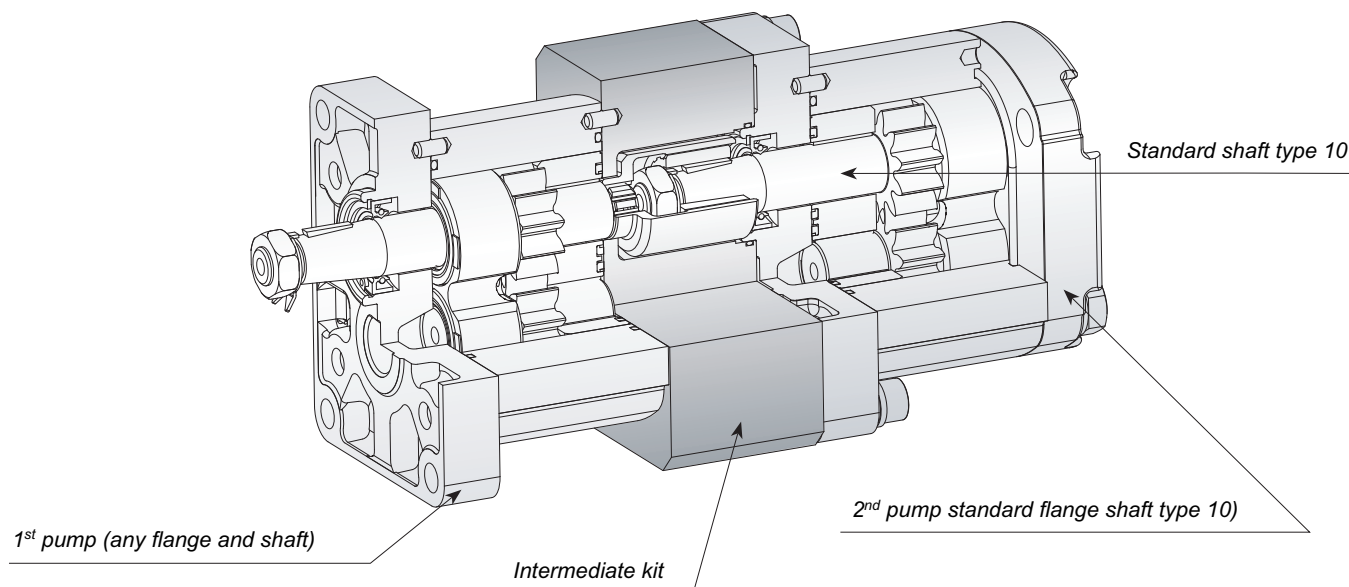

Example of ordering code

2SP A14 + 1SP A4.2 D SAE A - 10 G (VT)

2SP A14	First pump type	
1SP A4.2	Second pump type	
D	Clockwise rotation	D = Clockwise rotation S = Anticlockwise rotation
SAE A	Flange and version first pump flange	See corresponding single pump
10	Shaft type first pump	
G	Connections type	
(VT)	Optional	

Example of ordering code

3SP A36 + 2SP A14 + 1SP A3.2 D SAE B - 10 G (VT)

3SP A36	First pump type	
2SP A14	Second pump type	
1SP A3.2	Third pump type	
D	Clockwise rotation	D = Clockwise rotation S = Anticlockwise rotation
SAE B	Flange and version first pump flange	See corresponding single pump
10	Shaft type first pump	
G	Connections type	
(VT)	Optional	

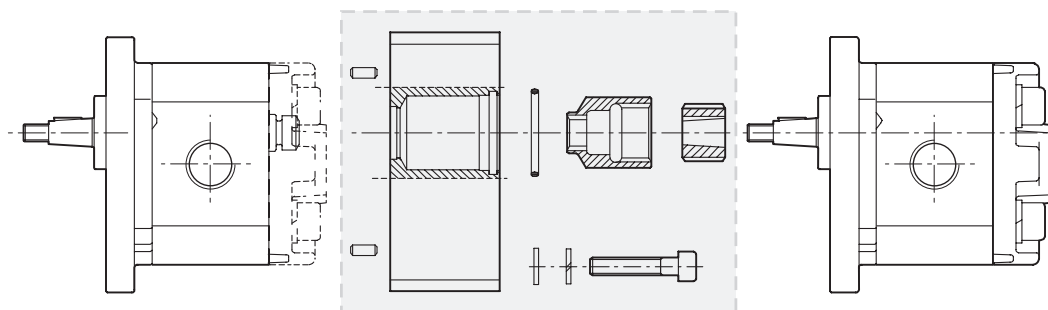

kit order code **01091100000000**

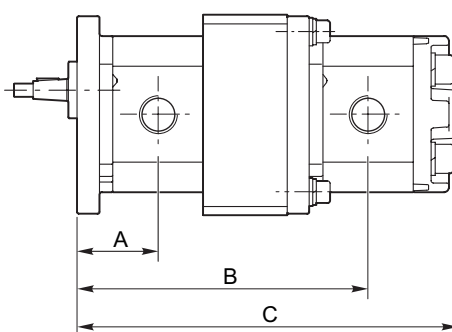

kit order code **01091100000000**

mm (inch)

	A	B	C
A9.8	52.2 (2.053)	177.9 (7.006)	234.1 (9.217)
A7.8	52.2 (2.053)	174.0 (6.850)	226.2 (8.906)
A6.3	52.2 (2.053)	171.2 (6.738)	220.5 (8.681)
A5.0	52.2 (2.053)	168.6 (6.638)	215.4 (8.480)
A4.2	52.2 (2.053)	167.1 (6.577)	212.3 (8.358)
A3.7	52.2 (2.053)	166.1 (6.539)	210.4 (8.283)
A3.2	52.2 (2.053)	165.1 (6.500)	208.4 (8.205)
A2.5	52.2 (2.053)	163.8 (6.447)	205.7 (8.098)
A2.0	52.2 (2.053)	162.8 (6.407)	203.7 (8.020)
A1.6	52.2 (2.053)	162.0 (6.378)	202.2 (7.961)
A1.2	52.2 (2.053)	161.2 (6.344)	200.5 (7.894)
A0.9	52.2 (2.053)	160.6 (6.323)	199.4 (7.850)

1SP A9.8 +

kit order code **01091100000000**

mm (inch)

	A	B	C
A7.8	48.2 (1.898)	166.1 (6.539)	218.3 (8.594)
A6.3	48.2 (1.898)	163.3 (6.427)	212.6 (8.370)
A5.0	48.2 (1.898)	160.7 (6.327)	207.5 (8.169)
A4.2	48.2 (1.898)	159.2 (6.266)	204.4 (8.047)
A3.7	48.2 (1.898)	158.2 (6.228)	202.5 (7.972)
A3.2	48.2 (1.898)	157.2 (6.189)	200.5 (7.894)
A2.5	48.2 (1.898)	155.9 (6.136)	197.8 (7.787)
A2.0	48.2 (1.898)	154.9 (6.096)	195.8 (7.709)
A1.6	48.2 (1.898)	154.1 (6.067)	194.3 (7.650)
A1.2	48.2 (1.898)	153.3 (6.033)	192.6 (7.583)
A0.9	48.2 (1.898)	152.7 (6.012)	191.5 (7.539)

1SP A7.8 +

With SAE AA flange increase A, B, and C dimensions of 0.138 inch

SEE PAGE 301 FOR PRICES

kit order code 01091100000000

kit order code 01091100000000

		mm (inch)			
		A	B	C	
1SP A6.3	+	A6.3	45.4 (1.785)	157.6 (6.203)	206.9 (8.146)
		A5.0	45.4 (1.785)	155.0 (6.102)	201.8 (7.945)
		A4.2	45.4 (1.785)	153.5 (6.041)	198.7 (7.823)
		A3.7	45.4 (1.785)	152.5 (6.004)	196.8 (7.748)
		A3.2	45.4 (1.785)	151.5 (5.965)	194.8 (7.669)
		A2.5	45.4 (1.785)	150.2 (5.911)	192.1 (7.563)
		A2.0	45.4 (1.785)	149.2 (5.872)	190.1 (7.484)
		A1.6	45.4 (1.785)	148.4 (5.843)	188.6 (7.425)
		A1.2	45.4 (1.785)	147.6 (5.809)	186.9 (7.358)
		A0.9	45.4 (1.785)	147.0 (5.787)	185.8 (7.315)
1SP A5.0	+	A5.0	42.8 (1.685)	149.9 (5.902)	196.7 (7.744)
		A4.2	42.8 (1.685)	148.4 (5.841)	193.6 (7.622)
		A3.7	42.8 (1.685)	147.4 (5.803)	191.7 (7.547)
		A3.2	42.8 (1.685)	146.4 (5.764)	189.7 (7.469)
		A2.5	42.8 (1.685)	145.1 (5.711)	187.0 (7.362)
		A2.0	42.8 (1.685)	144.1 (5.671)	185.0 (7.283)
		A1.6TC	42.8 (1.685)	143.3 (5.642)	183.5 (7.224)
		A1.2TC	42.8 (1.685)	142.5 (5.608)	181.8 (7.157)
		A0.9TC	42.8 (1.685)	141.9 (5.587)	180.7 (7.114)
	1SP A4.2	+	A4.2TC	41.3 (1.624)	145.3 (5.719)
		A3.7TC	41.3 (1.624)	144.3 (5.681)	188.6 (7.425)
		A3.2TC	41.3 (1.624)	143.3 (5.642)	186.6 (7.346)
		A2.5TC	41.3 (1.624)	141.9 (5.589)	183.9 (7.240)
		A2.0TC	41.3 (1.624)	140.9 (5.549)	181.9 (7.161)
		A1.6TC	41.3 (1.624)	140.2 (5.520)	180.4 (7.102)
		A1.2TC	41.3 (1.624)	139.4 (5.486)	178.7 (7.035)
		A0.9TC	41.3 (1.624)	138.8 (5.465)	177.6 (6.992)

		mm (inch)					
		A	B	C			
1SP A3.7	+	A3.7TC	40.3 (1.587)	142.4 (5.606)	186.7 (7.350)		
		A3.2TC	40.3 (1.587)	141.4 (5.567)	184.7 (7.272)		
		A2.5TC	40.3 (1.587)	140.1 (5.514)	182.0 (7.165)		
		A2.0TC	40.3 (1.587)	139.1 (5.474)	180.0 (7.087)		
		A1.6TC	40.3 (1.587)	138.3 (5.445)	178.5 (7.028)		
		A1.2TC	40.3 (1.587)	137.5 (5.411)	176.8 (6.961)		
		A0.9TC	40.3 (1.587)	136.9 (5.390)	175.7 (6.917)		
	1SP A3.2	+	A3.2TC	39.3 (1.547)	139.4 (5.488)	182.7 (7.193)	
			A2.5TC	39.3 (1.547)	138.1 (5.435)	180.0 (7.087)	
			A2.0TC	39.3 (1.547)	137.1 (5.396)	178.0 (7.008)	
		A1.6TC	39.3 (1.547)	136.3 (5.366)	176.5 (6.949)		
		A1.2TC	39.3 (1.547)	135.5 (5.333)	174.8 (6.882)		
		A0.9TC	39.3 (1.547)	134.9 (5.311)	173.7 (6.839)		
1SP A2.5		+	A2.5TC	37.9 (1.494)	135.4 (5.329)	177.3 (6.980)	
			A2.0TC	37.9 (1.494)	134.4 (5.289)	175.3 (6.902)	
			A1.6TC	37.9 (1.494)	133.6 (5.260)	173.8 (6.843)	
			A1.2TC	37.9 (1.494)	132.8 (5.226)	172.1 (6.776)	
		A0.9TC	37.9 (1.494)	132.2 (5.205)	171.0 (6.732)		
	1SP A2.0	+	A2.0TC	36.9 (1.455)	132.4 (5.211)	173.3 (6.823)	
			A1.6TC	36.9 (1.455)	131.6 (5.181)	171.8 (6.764)	
			A1.2TC	36.9 (1.455)	130.8 (5.148)	170.1 (6.697)	
			A0.9TC	36.9 (1.455)	130.2 (5.126)	169.0 (6.654)	
		1SP A1.6	+	A1.6TC	36.2 (1.425)	130.1 (5.122)	170.3 (6.705)
			A1.2TC	36.2 (1.425)	129.3 (5.089)	168.6 (6.638)	
			A0.9TC	36.2 (1.425)	128.7 (5.067)	167.5 (6.594)	
1SP A1.2			+	A1.2TC	35.4 (1.392)	127.6 (5.022)	166.9 (6.571)
				A0.9TC	35.35 (1.392)	127.0 (5.000)	165.8 (6.528)
			1SP A0.9	+	A0.9TC	34.8 (1.370)	125.9 (4.957)

SEE PAGE 301 FOR PRICES

Definition of pressures

The pumps can be subjected to the pressures P1, P2 or P3 indicated in the performance tables. The following diagram illustrates the definitions and applicability of these, compared to the rotation speed limits included.

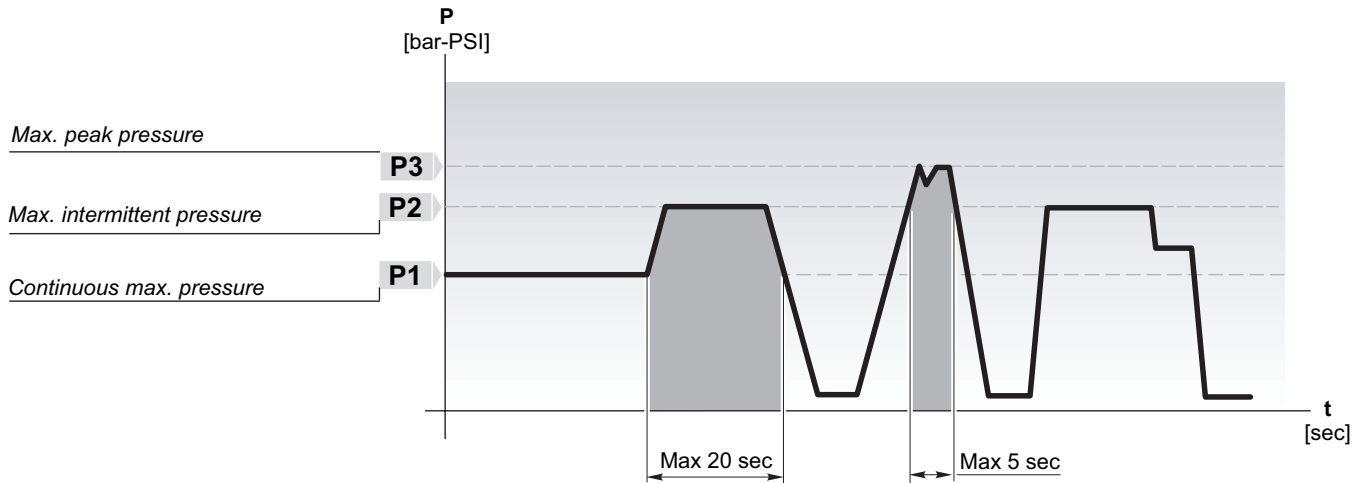

Hydraulic measures

Q Flow	[l/min - Gal/min]
M Torque	[Nm - lbf.in]
P Power	[kW - HP]
V Displacement	[cm ³ /rev - in ³ /rev]
N Speed	[min ⁻¹ - rpm]
Δp Pressure	[bar - PSI]

η_v Volumetric efficiency

η_m Mechanical efficiency

Useful formulas

$$Q = V \text{ [cm}^3\text{/rev]} \times \eta_v \times n \times 10^{-3} \quad \text{l/min}$$

$$M = \frac{\Delta p \text{ [bar]} \times V \text{ [cm}^3\text{/rev]}}{62.83 \times \eta_m} \quad \text{Nm}$$

$$P = \frac{\Delta p \text{ [bar]} \times V \text{ [cm}^3\text{/rev]} \times n}{600 \times 1000 \times \eta_t} \quad \text{kW}$$

Conversion factors

1 l/min = 0.2641 US Gal/min
1 Nm = 8.851 in-lbs
1 Nm = 0.7375 ft-lbs
1 N = 0.2248 lbs
1kW = 1.34 HP
1cm ³ /giro = 0.061 in ³ /rev
1 bar = 14.5 PSI
1 mm = 0.0394 in
1 kg = 2.205 lbs

Hydraulic fluids

It is advisable to use hydraulic oils of mineral origin with anti-foaming, anti-oxidant and anti-corrosion characteristics and a high viscosity index;

- Recommended viscosity $15 \div 92 \text{ mm}^2/\text{s}$ (cSt)
- Start-up viscosity limit $3000 \text{ mm}^2/\text{s}$ (cSt)

During normal operation, the temperature of the oil must be between 20°C and 65°C and limit values between -15°C and 80°C .

Suction pressure

The allowed working pressure supplied must be in the range $0.7 - 3 \text{ bar}$ (absolute).

For higher values (up to 30 bar), versions with a K seal must be used.

Suction and delivery pipes

Particular attention must be given to the sizing of pipes (rigid or flexible), avoiding disproportionate lengths, sudden variations in cross section or small curvature radius, in any case selecting pipe cross-sections that guarantee an oil speed between 0.6 and 12 m/s .

Filtration

In order to eliminate any impurities present in the oil and to guarantee a longer duration of the pump, the system must be equipped with effective filtration which must be periodically checked to ensure that it is operating correctly.

The following are the recommended filtration levels:

- $26/23 \text{ ISO DIS 4406}$ up to 150 bar
- $23/20 \text{ ISO DIS 4406}$ for higher pressures.

Installation notes

- Make sure that the coupling used for pulling compensates for any axial misalignments that could compromise the integrity of the pump.
- If there are radial and/or axial/ loads on the pump shaft (as is the case, for example, when pulling is carried out using pulleys and belts) the versions available with a support must be chosen.
- The connection coupling between spline shafts must be appropriately lubricated, free to move axially and of an adequate length to cover the entire extension of the two shafts (motor and pump).
- If the pump is painted, protect the shaft seal and also make sure that the contact zone between the shaft seal and the shaft is free of dust or abrasive sediments.

Rotation direction

The rotation direction is defined as S (left/anticlockwise) or D (right/clockwise) by observing the shaft from the front.

The pumps are monodirectional and therefore when ordering the required rotation direction must be specified; alternatively it is possible to modify the internal set-up as illustrated below (inversion of the rotation direction).

The pages regarding the pump characteristics highlight the directions of the delivery and suction flows for each version and rotation direction.

Pressure drops

The following nomogram allows you to calculate the pressure drops for each 100 m of piping when the viscosity of the oil, the delivery capacity of the pump and the diameter of the piping are known.

The viscosity (V), flow capacity (Q) and diameter (D) values are fixed on the respective scales; a line is drawn joining the points V and Q; the point where this intersects the index line is defined as point I. If the line joining point I to point D is extended, the load pressure drops value can then be read at the intersection with the last scale.

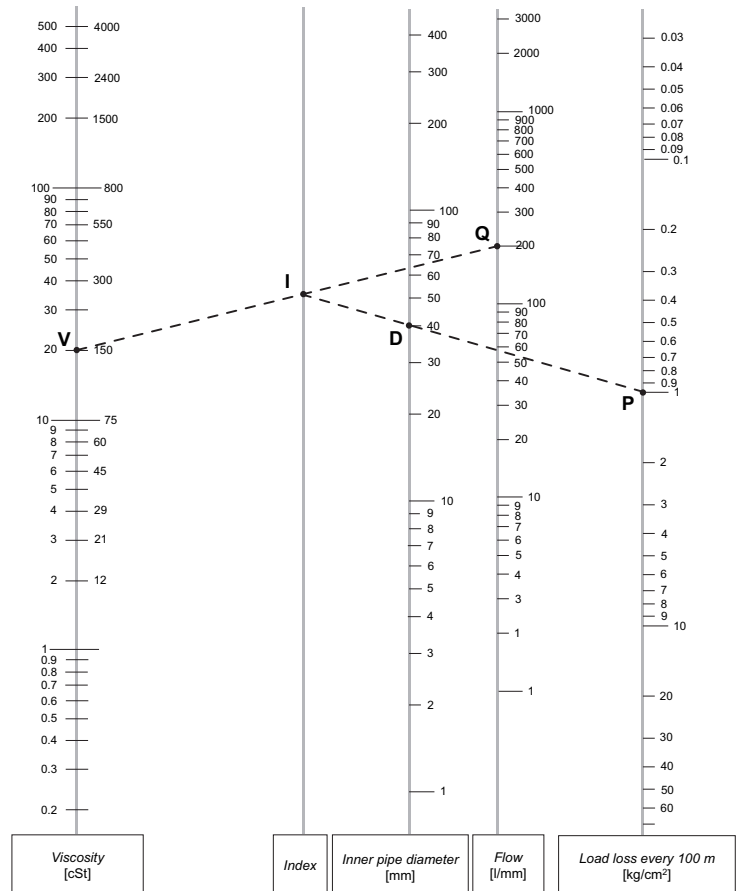

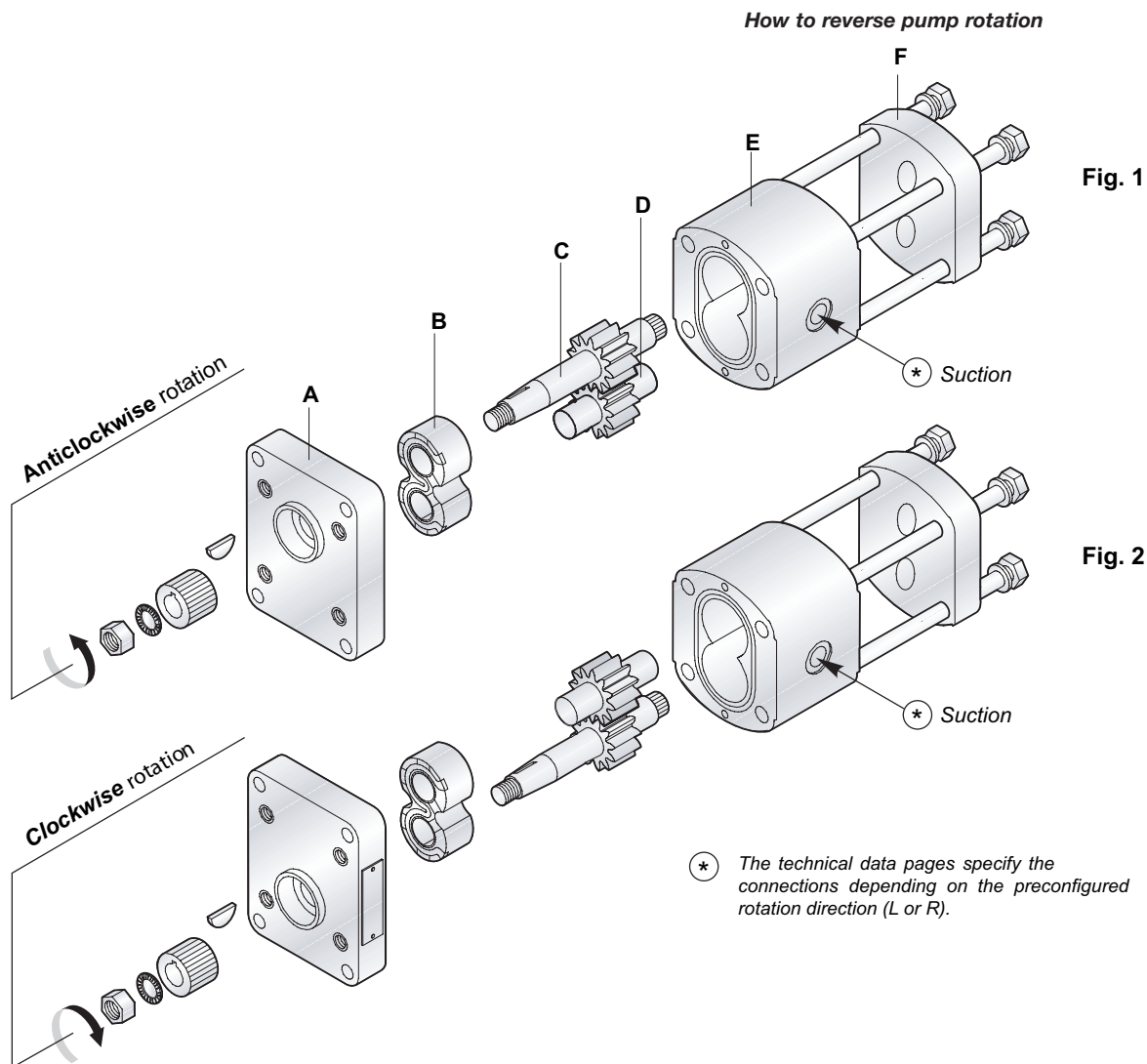

The gear pumps direction of rotation is indicated by an arrow on the label.

How to reverse the pumps rotation:

- Disassemble pump as shown in figure 1.
- Pull off gears C - D and reassemble according to figure 2.
- Reassemble bushing B as before.
- Reverse the flange A and reassemble the pump tightening the screws by using a torque wrench.
- For the pumps GR3 - GR4, disassemble only front flange.

Type of pump	GR1	GR2	GR3	GR4
Numbers of screws	4	4	16	16
Type of threads	M8	M10	M10	M14
Tightening torque of screws	30 Nm (266 in-lbs)	50 Nm (443 in-lbs)	60 Nm (531 in-lbs)	140 Nm (1239 in-lbs)
Type of coupling	1IS 12M	2IS 14M 2IS 15M	3IS 18M	4IS 23M
Tightening torque at nut coupling	9 ÷ 10 Nm (80 ÷ 89 in-lbs)	22 ÷ 25 Nm (195 ÷ 221 in-lbs) 32 ÷ 35 Nm (283 ÷ 310 in-lbs)	50 ÷ 55 Nm (443 ÷ 487 in-lbs)	100 ÷ 120 Nm (885 ÷ 1062 in-lbs)

Flow - Speed chart

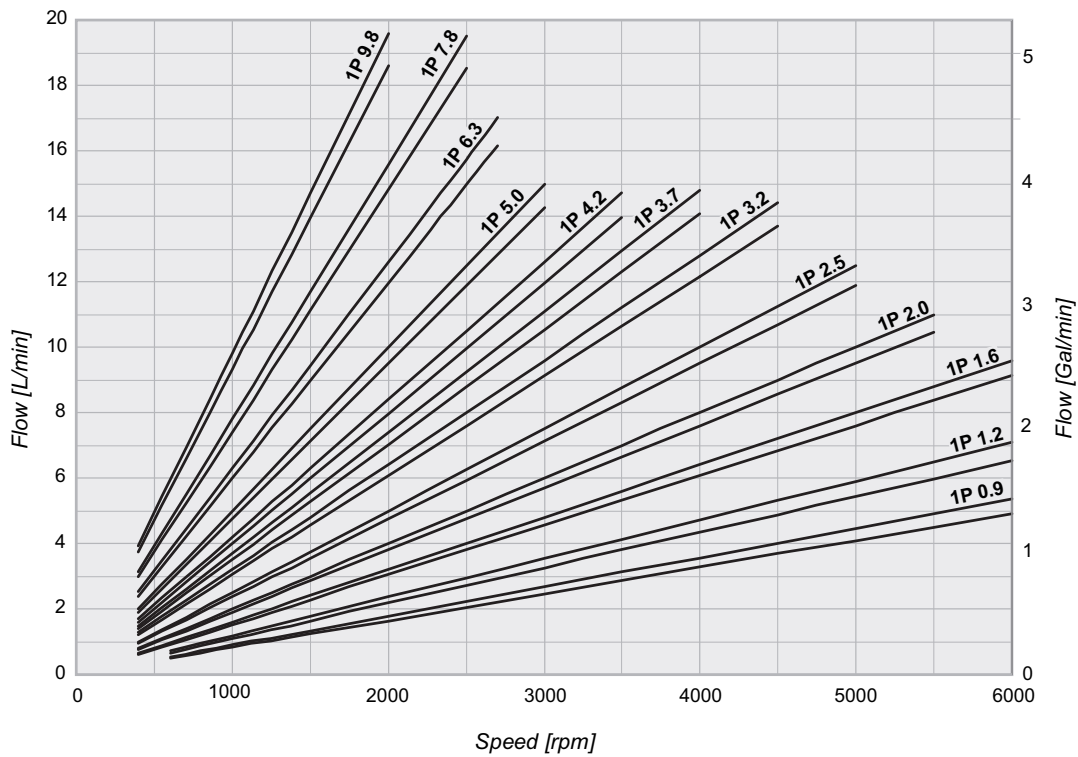

Pumps Group 1 Power and Speed Diagrams

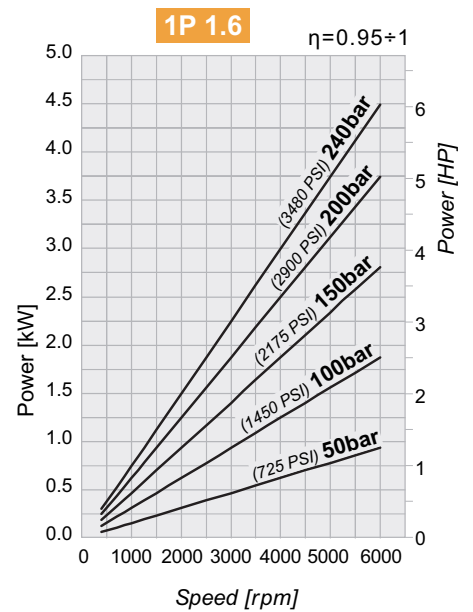
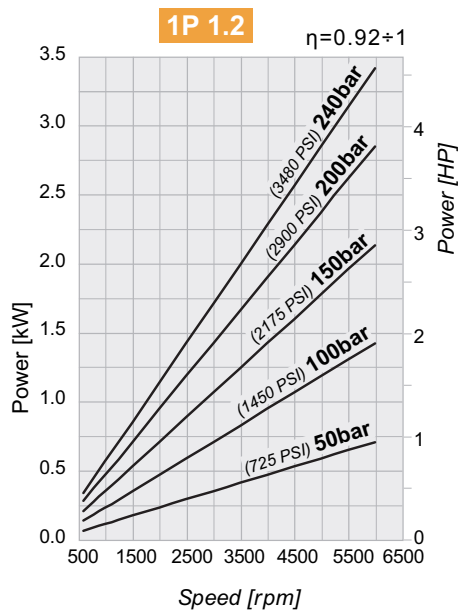
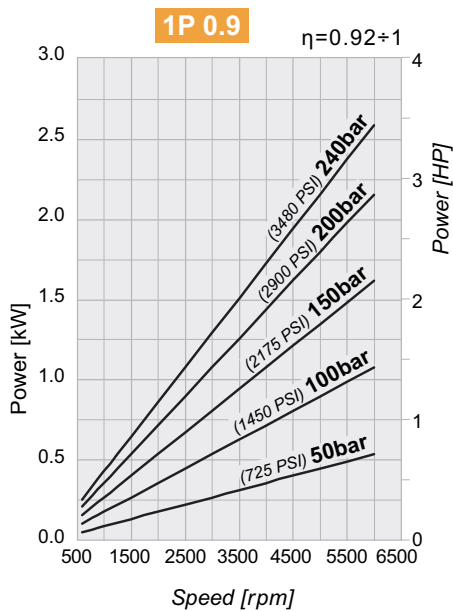

PUMPS GROUP 1 • PERFORMANCE



Pumps Group 1 Power and Speed Diagrams

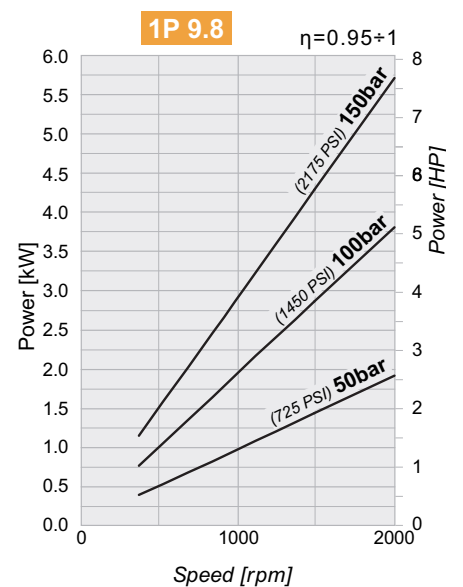
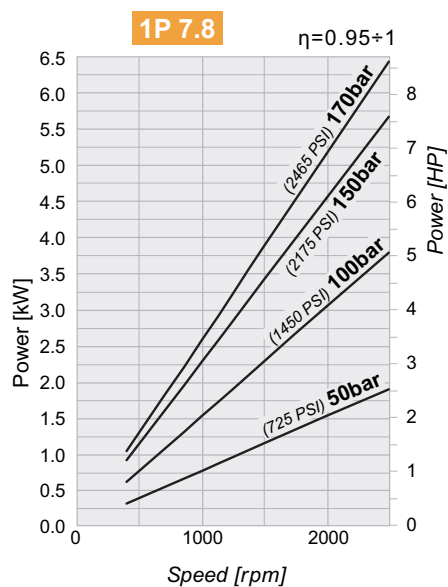
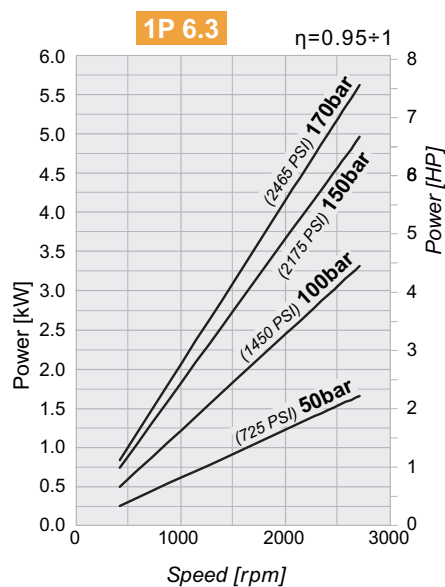
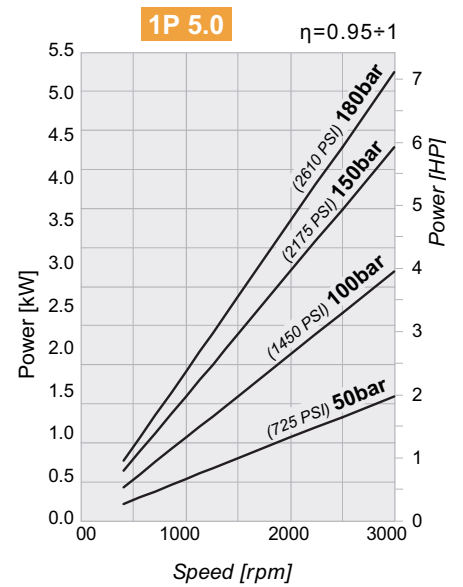
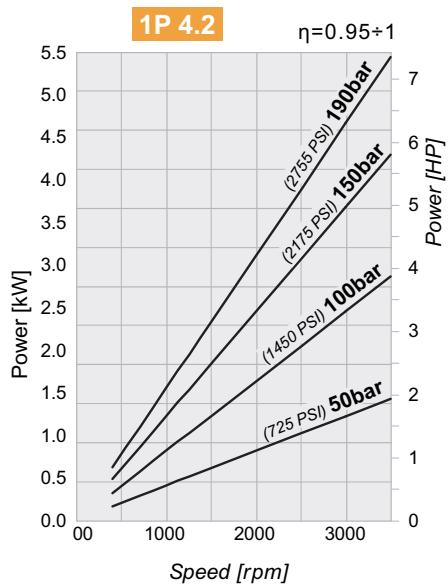
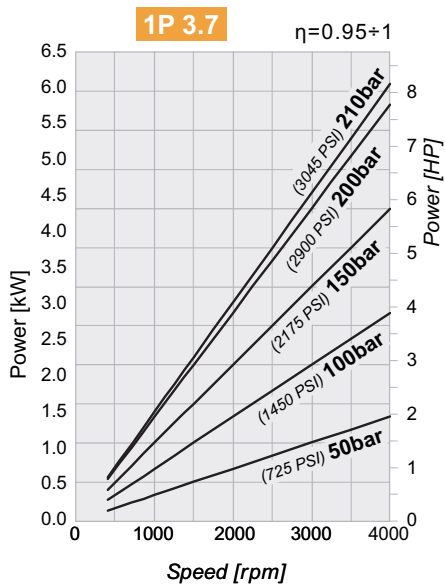
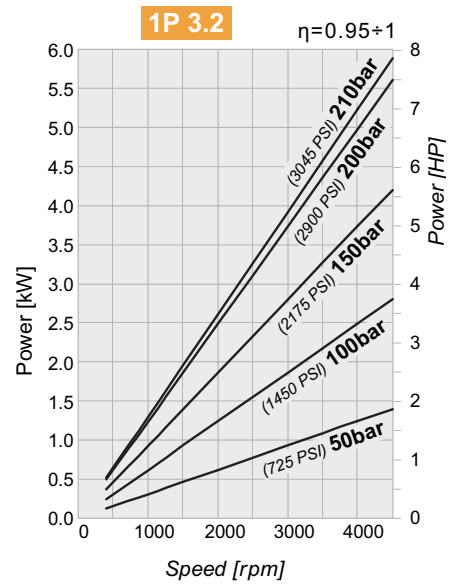
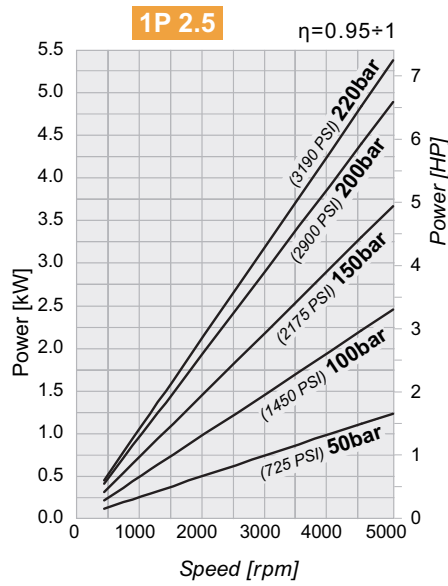
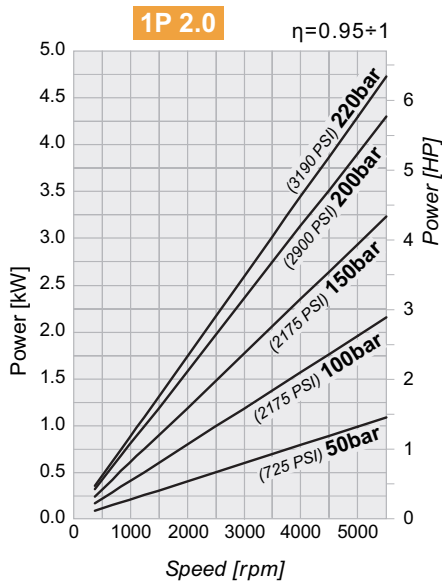

PUMPS GROUP 1 • STANDARD



Technical data

Size	Displacement [cm ³ /rev] (in ³ /rev)	Max. working pressure			Max. speed [g/min] (rpm)	Max. flow [l/min] (Gal/min)	Min. speed [g/min] (rpm)	Min. flow [l/min] (Gal/min)	Dimensions		Mass [Kg] (lbs)	Min. volumetric efficiency %
		P1 [bar] (PSI)	P2 [bar] (PSI)	P3 [bar] (PSI)					A [mm] (inch)	B [mm] (inch)		
1SP A0.9	0.89 (0.05)	240 (3480)	260 (3770)	290 (4205)	6000	5.3 (1.40)	600	0.49 (0.13)	34.80 (1.370)	73.6 (2.898)	0.91 (2.01)	92*
1SP A1.2	1.18 (0.07)	240 (3480)	260 (3770)	290 (4205)	6000	7.1 (1.88)	600	0.65 (0.17)	35.35 (1.392)	74.7 (2.941)	0.93 (2.05)	
1SP A1.6	1.6 (0.10)	240 (3480)	260 (3770)	290 (4205)	6000	9.6 (2.54)	400	0.61 (0.16)	36.20 (1.425)	76.4 (3.008)	0.95 (2.09)	
1SP A2.0	2.0 (0.12)	220 (3190)	250 (3625)	270 (3915)	5500	11 (2.91)	400	0.76 (0.20)	36.95 (1.455)	77.9 (3.067)	0.97 (2.14)	95*
1SP A2.5	2.5 (0.15)	220 (3190)	250 (3625)	270 (3915)	5000	12.5 (3.30)	400	0.95 (0.25)	37.95 (1.494)	79.9 (3.146)	1.00 (2.21)	
1SP A3.2	3.2 (0.20)	210 (3045)	240 (3480)	260 (3770)	4500	14.4 (3.80)	400	1.21 (0.32)	39.30 (1.547)	82.6 (3.252)	1.04 (2.29)	
1SP A3.7	3.7 (0.23)	210 (3045)	240 (3480)	260 (3770)	4000	14.8 (3.91)	400	1.40 (0.37)	40.30 (1.587)	84.6 (3.331)	1.07 (2.36)	
1SP A4.2	4.2 (0.26)	190 (2755)	210 (3045)	230 (3335)	3500	14.7 (3.88)	400	1.60 (0.42)	41.25 (1.624)	86.5 (3.406)	1.10 (2.43)	
1SP A5.0	5.0 (0.31)	180 (2610)	210 (3045)	230 (3335)	3000	15 (3.96)	400	1.90 (0.50)	42.80 (1.685)	89.6 (3.528)	1.14 (2.51)	
1SP A6.3	6.3 (0.38)	170 (2465)	190 (2755)	210 (3045)	2700	17 (4.49)	400	2.39 (0.63)	45.35 (1.785)	94.7 (3.728)	1.22 (2.69)	
1SP A7.8	7.76 (0.47)	170 (2465)	190 (2755)	210 (3045)	2500	19.4 (5.13)	400	2.95 (0.78)	48.20 (1.898)	100.4 (3.953)	1.30 (2.87)	
1SP A9.8	9.78 (0.60)	150 (2175)	170 (2465)	190 (2755)	2000	19.6 (5.18)	400	3.71 (0.98)	52.15 (2.053)	108.3 (4.264)	1.41 (3.11)	

* Value collected during the testing at 1500 rpm

Example of ordering code

1SP	A	2.0	D	(H)	-	10	GG	0	(VT)
-----	---	-----	---	-----	---	----	----	---	------

1SP	Pump type	see table
A	Flange and cover material	A = Aluminium
2.0	Displacement	see table
D	Clockwise rotation	D = Clockwise rotation S = Anticlockwise rotation
(H)	Stiffening seal for low suction pressure	(optional)
— ⁽¹⁾	Standard flange	
10	Shaft type	10 - 11 - 13 - 14 - 15 - 27
GG	Port connection type	GG - NN - TT - UU - NG - TG - UG
0	Connections positions	0 - 1 - 3 - 4
(VT)	Optional	(VT) Viton seals (optional) VLP-I (N) Pressure relief valve (page A-27)

⁽¹⁾ It is not necessary to indicate STANDARD flange

Conn Port Connections

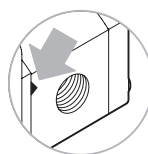
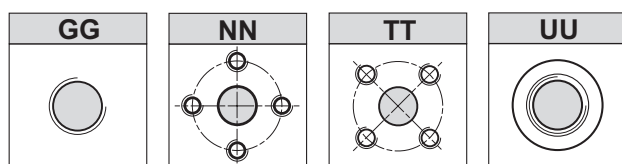

The sign on the body identifies the **suction side** for the pumps.

Connection positions

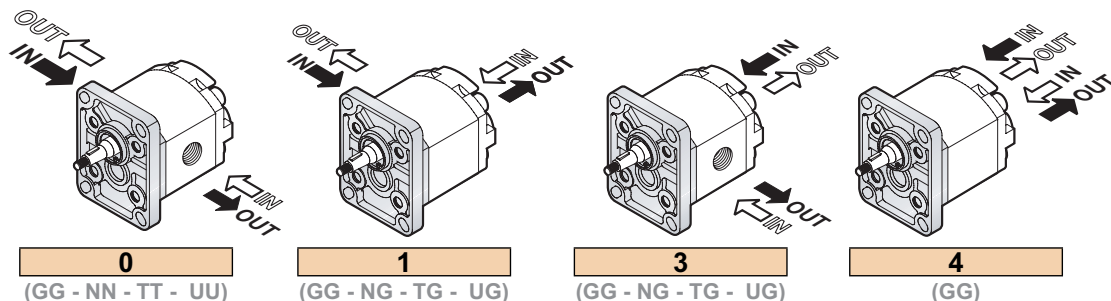

Rotation	
D	S

SEE PAGE 285 FOR PRICES

Dimensions mm (inch)

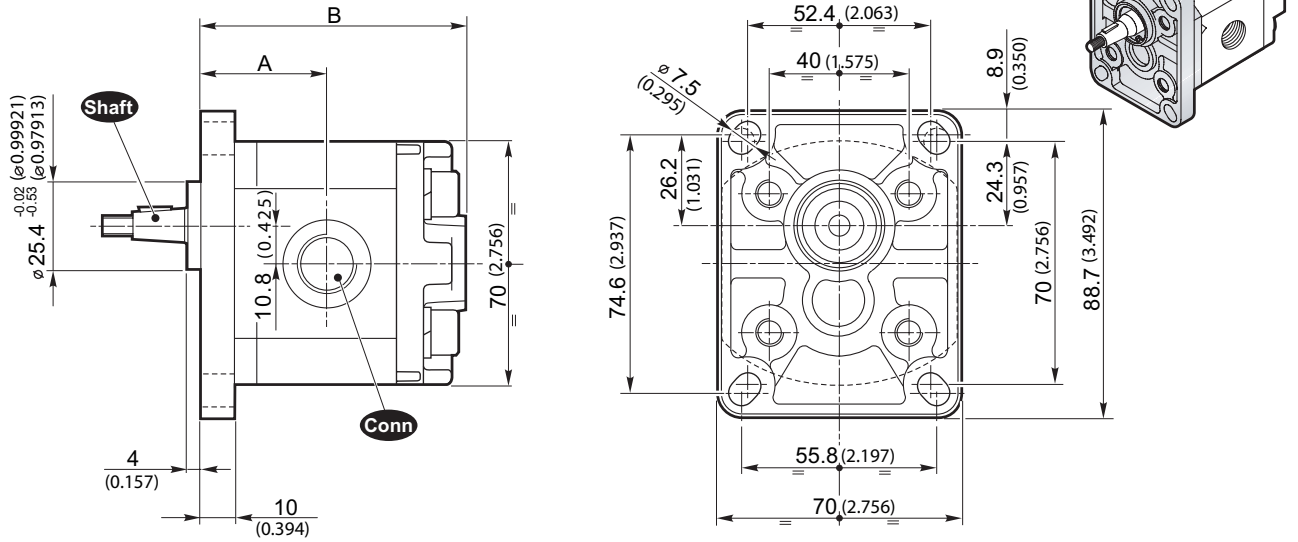

Shaft Available shafts

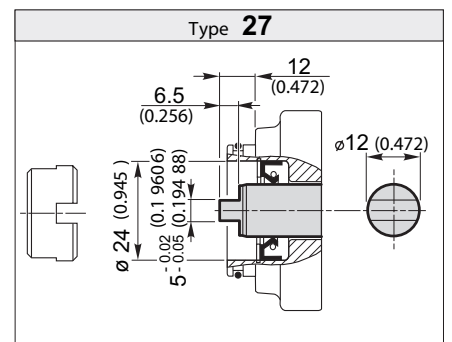
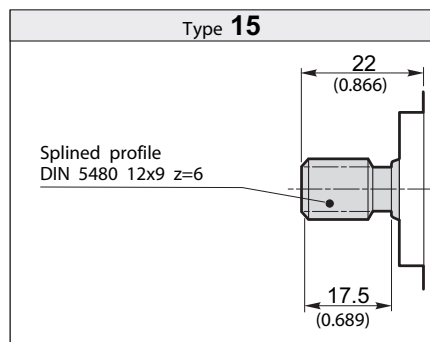
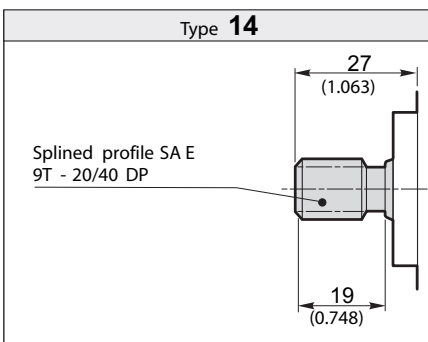
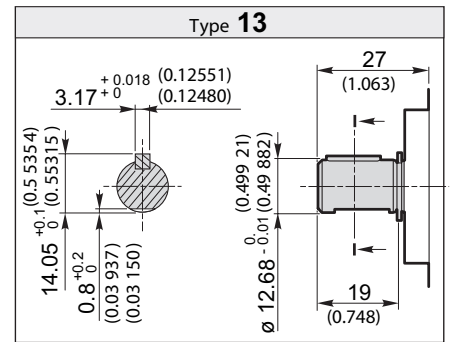
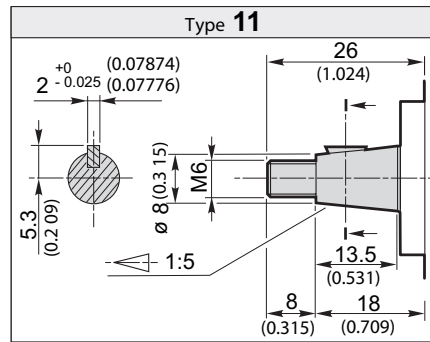
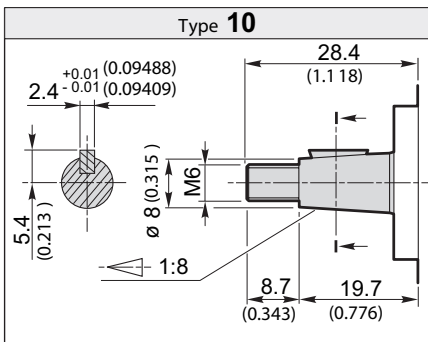

SEE PAGE 247 FOR PORT SIZES AVAILABLE

SEE PAGE 285 FOR PRICES

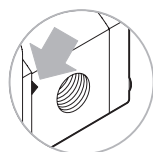
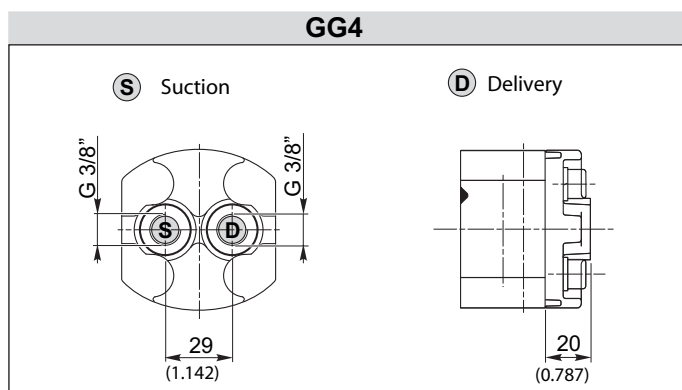
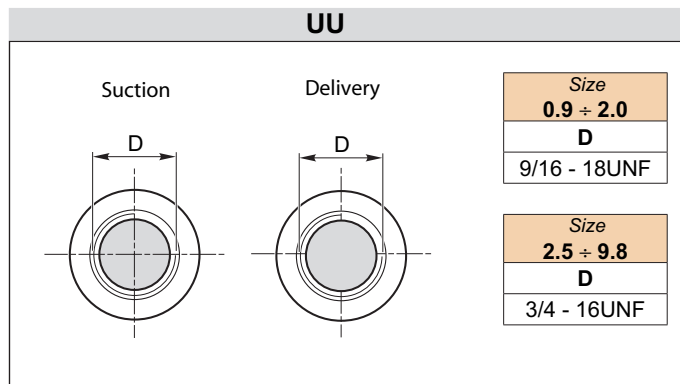
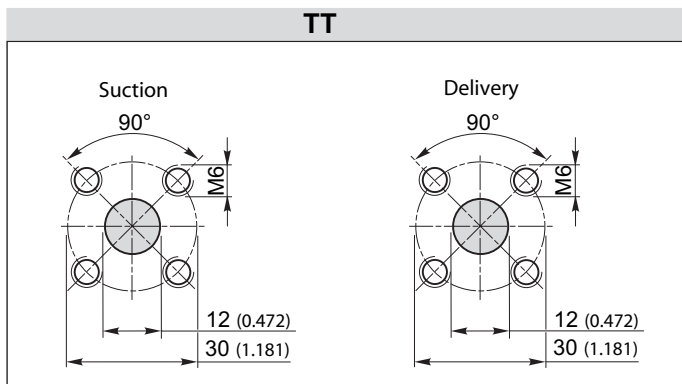
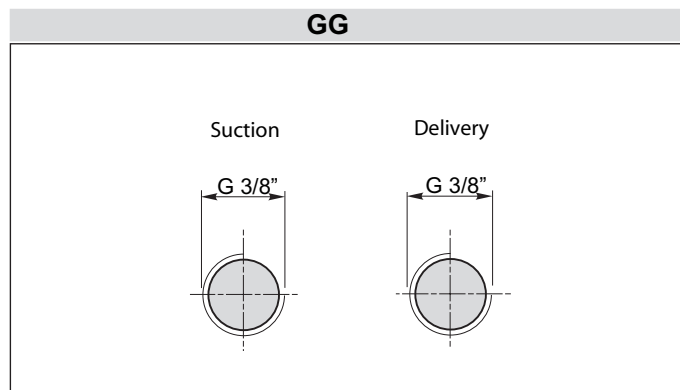
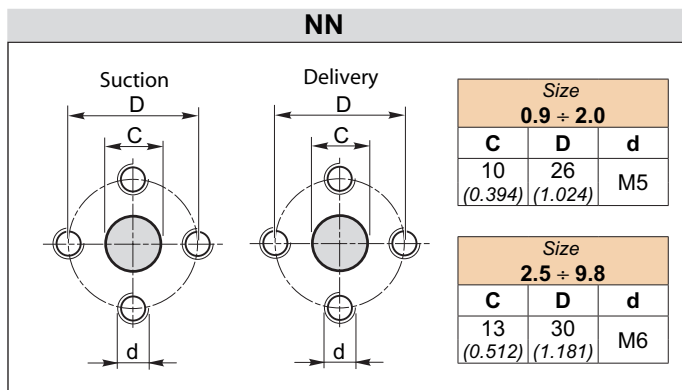

The sign on the body identifies the **suction side** for the pumps.

Port Connection positions

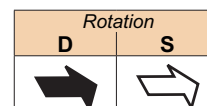
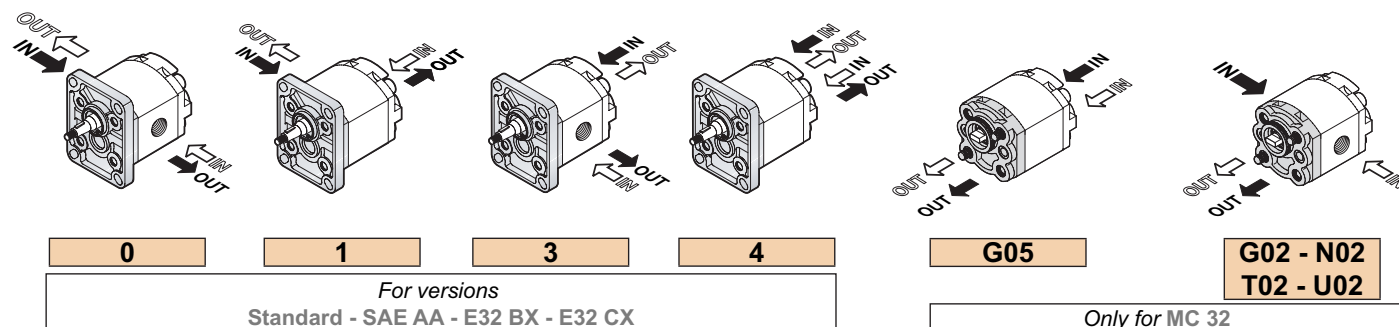

SEE PAGE 285 FOR PRICES

VLP- I (N)

Pressure relief valve

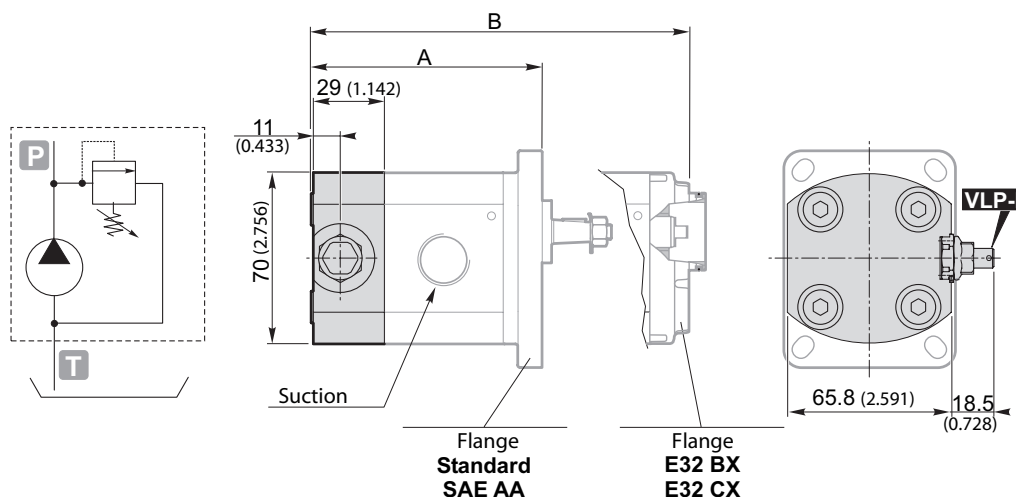
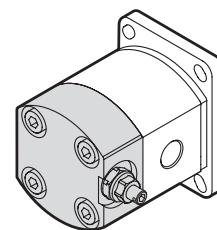

	A		B
	Standard	SAE AA	E32 BX E32 CX
1SP A0.9	82.6 (3.252)	86.1 (3.390)	82.6 (3.252)
1SP A1.2	83.7 (3.295)	87.2 (3.433)	83.7 (3.295)
1SP A1.6	85.4 (3.362)	88.9 (3.500)	85.4 (3.362)
1SP A2.0	86.9 (3.421)	90.4 (3.559)	86.9 (3.421)
1SP A2.5	88.9 (3.500)	92.4 (3.638)	88.9 (3.500)
1SP A3.2	91.6 (3.606)	95.1 (3.744)	91.6 (3.606)
1SP A3.7	93.6 (3.685)	97.1 (3.823)	93.6 (3.685)
1SP A4.2	95.5 (3.760)	99.0 (3.898)	95.5 (3.760)
1SP A5.0	98.6 (3.882)	102.1 (4.020)	98.6 (3.882)
1SP A6.3	103.7 (4.083)	107.2 (4.220)	103.7 (4.083)
1SP A7.8	109.4 (4.307)	112.9 (4.445)	109.4 (4.307)
1SP A9.8	117.3 (4.618)	120.8 (4.756)	117.3 (4.618)

Warning.

The pressure relief valve can be applied by substituting the rear cover (only internal relief is set).

The opening of the pressure relief valve should be carry out for times not over 10" each minute to avoid the overheating of the pump.

Esempio di ordinazione in codice / Example of ordering code

1SP	A	2.5	D	SAE AA	-	10	GG0	VLP-I	(N)
-----	---	-----	---	--------	---	----	-----	-------	-----

VLP-I	Cover with VPL at internal exhaust	VPL-I
(N)	Spring type	B - N - G - R (See table)

		Spring type			
		B	N	G	R
		white spring	black spring	yellow spring	red spring
Calibration fields*	[bar] (psi)	30 ÷ 80 (435 ÷ 1160)	81 ÷ 200 (1175 ÷ 2900)	201 ÷ 300 (2915 ÷ 4350)	301 ÷ 400 (4365 ÷ 5800)

* Without setting request, it will be considered standard (black spring: 1740 psi).